

RISH ED 1100 - Direct connected Energy Meter Din Mount 2U Installation Guide



Measurement and Energy / Counter Screen
Enter Key
Scroll Key

The Direct Connected Energy Meter is a DIN Rail mounted static energy meter used for metering and sub metering applications in industrial, commercial and residential applications. Meter accurately measures important electrical parameters like voltage, current, frequency, power factor, active, reactive, apparent power and energies. The meter is engineered using advanced micro controller technology and is suitable for electrical parameter measurement and monitoring in 1 Phase 2 Wire Networks. It supports maximum 100 A current measurement on direct connection. It displays parameters on bright intuitive LCD and also has pulse outputs and Impulse LED for energy monitoring. It supports Tariff counters selectable via digital Input or RS485 communication. It has inbuilt industry standard MODBUS RTU for remote monitoring.

Safety Precautions:

All safety related codifications, symbols and instructions that appear in this operating manual or on the equipment must be strictly followed to ensure the safety of the operating person as well as the instrument.

If the equipment is not used in a manner specified by the manufacturer it might impair the protection provided by the equipment.

Do not use the equipment if there is any mechanical damage.

Ensure that the equipment is supplied with correct voltage.

1. Read complete instructions prior to installation and operation of the unit.

2. Risk of electric shock.

3. The equipment in its installed state must not come in close proximity to any heating sources, oils, steam, caustic vapors or other unwanted process by products.

4. Circuit breaker should be installed and preferably near equipment so that in case of hazards can be accessed easily for switching off the mains

Wiring Guidelines:

1. To prevent the risk of electric shock, power supply to the equipment must be Kept OFF while doing the wiring Arrangement.

2. Wiring shall be done strictly according to the terminal layout. Confirm that all connections are correct.

3. Use lugged terminals.

4. To reduce electromagnetic interference use of wires with adequate ratings and twists of the same in equal size shall be made with shortest connections.

5. Layout of connecting cables shall be away from any internal EMI source.

6. Cable used for connection to power source, must have cross section of 35mm² (13-11AWG, 75°C) These wires shall have current carrying capacity of 100A.

7. Copper cable should be used (Stranded or Single core cable).

8. Before attempting work on device, ensure absence of voltages using appropriate voltage detection device.

Installation Guidelines

1. This equipment, being normally becomes a part of main control panel and in such case the terminals do not remain accessible to the user end after installation and internal wiring.

2. Conductors must not come in contact with the internal circuitry of the equipment or else it may lead to a safety hazard that may in turn endanger life or cause electrical shock to the operator.

3. The equipment shall not be installed in environmental condition other than those mentioned in this manual.

4. Connector screw must be tightened after installation.

Dimension: 35 x 90 x 65 mm

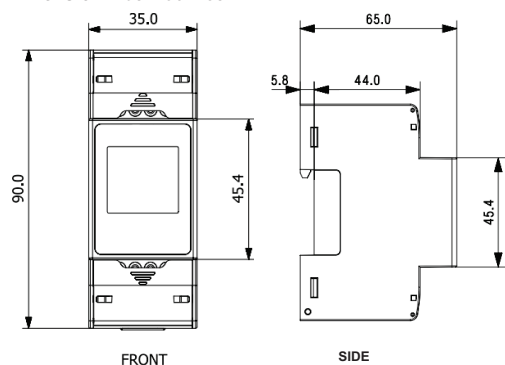

Connection Terminals Detail:

- 1,2 - Neutral
- 3 - Line In
- 4 - Line out
- 5,6 - SO1 Output
- 9,10 - SO2 Output
- 11,12 - DI / TARIFF SIGNAL

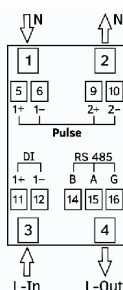

Specifications:

Input :

- Connections: 1 Phase 2 Wire
- Input voltage: Reference Voltage (Un) 230 VLN
- Operating Voltage Range : 184 - 276 VLN
- Power consumption in Voltage Circuit : < 2 W (10 VA)
- Starting Current (Ist = 0.04*Itr) 20 mA
- Minimum Current (Imin (0.5*Itr) 250 mA
- Transitional Current (Itr) 0.5 A
- Reference Current (Iref) (10*Itr) 5 A
- Maximum Current (Imax) > (50*Itr) 100 A
- Operating Current Range 0.25-5 A
- Short time Over-current 30*I_{max} for half-cycle at 50 Hz
- Power consumption in Current Circuit < 1 VA
- Frequency 45-65 Hz

Accuracy :

- Active Energy (Import/Export) Class B as per EN50470-3, Class 1 as per IEC 62053-21
- Reactive Energy (Import/Export) Class 2 as per IEC62053-23
- Apparent Energy ± 1.0 %
- Voltage ± 0.5% of of range max
- Current ± 0.5% of Nominal value
- Frequency ± 0.2% of Mid frequency
- Active Power ± 1% of range max
- Reactive Power ± 1% of range max
- Apparent Power ± 1% of range max
- Power Factor ± 1% of unity

Pulse Outputs :

- SO1 and SO2 Passive Opto-isolated
- Contact Ranges 5 - 27V DC, 27 mA DC (max)
- Pulse Duration 60 / 100 / 200 millisecond
- Pulse Rate 1 / 10 / 100 / 1000 pulse per kWh
- Impulse Rate 1000 pulse per kWh

Communication Interface :

- Protocol RS485 MODBUS RTU
- Baudrate 4.8 / 9.6 / 19.2 / 38.4 kbit
- Data Width 8
- Parity Stop Bits None -1 / None -2/ Even -1 / Odd -1
- Device Address 1- 247
- Response Time < 300 millisecond

TABLE 1 : Measurement Parameters:

1. Screen1

Parameter No.	Parameters	On Display	On Modbus
1	Import Active Energy	✓	✓
2	Export Active Energy	✓	✓
3	Total Active Energy	✓	✓
4	Import Reactive Energy	✓	✓
5	Export Reactive Energy	✓	✓
6	Total Reactive Energy	✓	✓
7	Total Apparent Energy	✓	✓
8	Partial Import Active Energy	✓	✓
9	Partial Export Active Energy	✓	✓
10	Partial Total Active Energy	✓	✓
11	Partial Import Reactive Energy	✓	✓
12	Partial Export Reactive Energy	✓	✓
13	Partial Total Reactive Energy	✓	✓
14	Partial Total Apparent Energy	✓	✓
15	Voltage	✓	✓
16	Current	✓	✓
17	Active Power	✓	✓
18	Reactive Power	✓	✓
19	Apparent Power	✓	✓
20	Power Factor	✓	✓
21	Frequency	✓	✓
22	Cst - xxxx	✓	✓
23	Add - xxx	✓	✓
24	bd - xxxx	✓	✓
25	Pd - Pd count of meter	✓	✓
26	Active tariff status	✓	✓
27	Serial Number	✓	✓
28	Display Test	✓	--

TABLE 1 : Measurement Parameters (contd.):

2. Screen 2

Parameter No.	Parameters	On Display	On Modbus
29	T1 Export Active Energy	✓	✓
30	T1 Total Active Energy	✓	✓
31	T1 Import Reactive Energy	✓	✓
32	T1 Export Reactive Energy	✓	✓
33	T1 Total Reactive Energy	✓	✓
34	T1 Total Apparent Energy	✓	✓
35	T2 Import Active Energy	✓	✓
36	T2 Export Active Energy	✓	✓
37	T2 Total Active Energy	✓	✓
38	T2 Import Reactive Energy	✓	✓
39	T2 Export Reactive Energy	✓	✓
40	T2 Total Reactive Energy	✓	✓
41	T2 Total Apparent Energy	✓	✓
42	Import W Max Demand	✓	✓
43	Export W Max Demand	✓	✓
44	Import VAr Max Demand	✓	✓
45	Export VAr Max Demand	✓	✓
46	Import VA Max Demand	✓	✓
47	Export VA Max Demand	✓	✓
48	Current Max Demand	✓	✓



LCD Functions:

2.1. Introduction

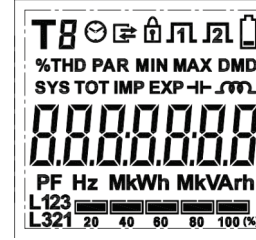

LCD is FSTN 7 segment display with backlight with symbols
 LCD displays all measurement and program menu screens
 Scroll key - Used in measurement mode to navigate screens
 switch screens and to change parameter value in program mode.
 Enter key Used to move cursor and confirm settings in program mode
 Example. To Set password 1234, Press Enter key to start editing the digit then use scroll key to increment digit value then use enter key to confirm digit value and move to next digit editing.

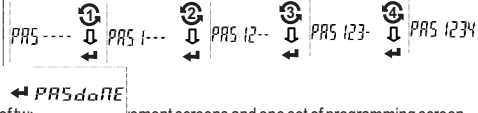

The meter displays parameters consist of two set of measurement screens and one set of programming screen
 Measurement screens are 1. Screen1 - Basic meter screen 2. Screen2 - Demand and tariff screens
 The user can easily scroll through parameter by pressing scroll key in both measurement screens. Press and holding scroll key for 4 seconds enable switching between measurement screens i.e. screen1 & screen2.
 Refer TABLE 1 on pag1 for list all the measurement parameters available with screen number

LCD Display Symbols and Indications

The LCD has bold seven segment digits, measurement parameter units and special symbols for effective display and easy onsite configuration.
 not all symbols may be used in particular meter type that is installed Indications for communication status and pulse outputs status and bar graph are continuously available on screen.
 Measurement screen can be set as automatic scrolling or manual scrolling.

SO Output Indication :

The meter has two opto-isolated pulse outputs that can be configured for any one of the Active, Reactive and Apparent Energy parameter.
 This symbol indicates that SO1 is energized.
 This symbol indicates that SO2 is energized.

Communication Indication :

The meter has communication port for accessing measurement data , configuration purpose.
 This symbol indicates Host communication is in progress

Bargraph Indication :

Measured meter current in percentage of meter maximum current rating is displayed by bargraph symbols

Tariff Indication : Meter has tariff function and indicated by symbol **T**, The digit after this symbol indicates tariff number either 1 or 2

Other Labels: DMD - Indicates demand parameter , PAR - Indicates partial energy parameter
 IMP - indicates Import parameter , EXP - indicates export parameter

Programming mode Screen :

Screen No.	Screen Label	Description of programming function	Parameter range / values	Default
1	Code	Enter password to allow programming	0000 - 9999	0000
2	Add	Device Address for communication	001 - 247	001
3	bd	Baud rate of communication	2.4 / 4.8 / 9.6 / 19.2 / 38.4 kbps	9.6
4	Prtly	Parity and stop bit of communication	None-2 / None-1/Even-1/Odd-1	None-2
5	PLS1OUT	Pulse1(SO1) parameter	kwh - imp / exp kvarh - imp / exp / ind / cap	kwh-imp
6	PLS2OUT	Pulse2(SO2) parameter	kwh - imp / exp kvarh - imp / exp / ind / cap	kwh-exp
7	cST	Pulse (SO1 and SO2) constant	1 / 10 / 100 / 1000	1000
8	PLST	Pulse (SO1 and SO2) on time	60 / 100 / 200 millisecond	200
9	dit	Demand integration time	5 - 30 Minutes	15
10	rST	Reset of Parameter	Partial energy/ PD / Dmd / All	None
11	SCrl	Auto scrolling of parameter	Yes / No	No
12	SetPASS	Set programming password	0000-9999	----
13	quit	Quit program mode	Yes / No	No

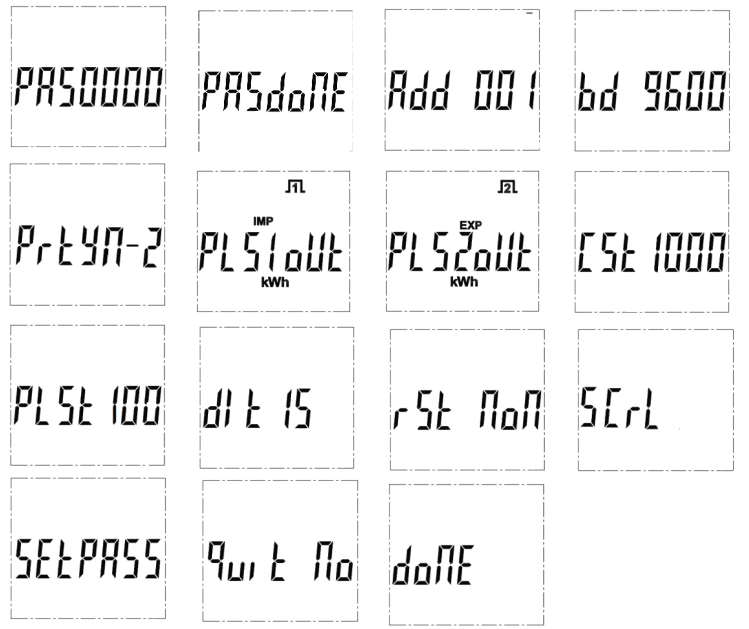

Tariff status - Input based and T1

Tariff status - MODBUS based - T1