

HDL-MR0416D.431
 4CH 16A High Power Switch Actuator (with Dry Contact)
 HDL-MR0816D.432
 8CH 16A High Power Switch Actuator (with Dry Contact)
 HDL-MR1216D.433
 12CH 16A High Power Switch Actuator (with Dry Contact)

buspro

Datasheet

Issued: May 6, 2021
 File Edition: V1.0.2



Figure 1. 4CH 16A High Power Switch Actuator (with Dry Contact)

Figure 2. 8CH 16A High Power Switch Actuator (with Dry Contact)



Figure 3. 12CH 16A High Power Switch Actuator (with Dry Contact)

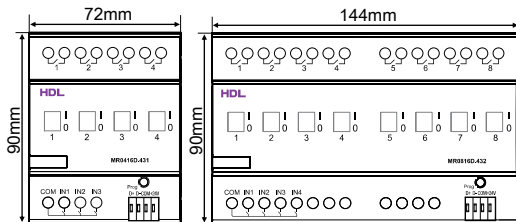

Figure 4. HDL-MR0416D.431

Figure 5. HDL-MR0816D.432

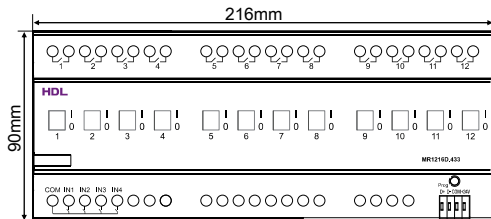

Figure 6. HDL-MR1216D.433

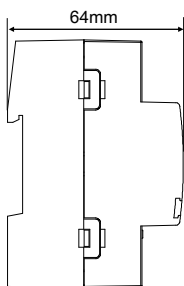

Figure 7

Figure 4-7. Dimensions

Overview

4(8/12)CH 16A High Power Switch Actuator (with Dry Contact) (See Figure 1-3) has 4/8/12 channels(16A for each channel) and 50A magnetic latching relay. With low power consumption and long lifetime, the module has manual control switches and supports scene and sequence control.

Functions

- 4/8/12-channel relay output unit
- 3/4/4 dry contact channels
- Scene control and sequence control
- Up to 4/8/12 separate zones
- Up to 13 scenes for each zone, and 12 of which are available for editing, scene running time up to 60 minutes
- 2 sequences for each zone, up to 12 steps for each sequence
- Light protection delay for each channel (0-60 minutes)
- Mass turn-on delay for each channel(0-25 seconds)
- Manual switch for each channel
- Stair lamp function of the channel settable
- Selected scene or scene before power off automatically activated when device restarts
- HDL Buspro communication
- Supports online upgrade

Important Notes

- Buspro cable - CAT5E or dedicated HDL Buspro cable
- Buspro connection - Series connection (hand-in-hand recommended).
- Maximum current for each output channel: 16A
- One 16A breaker for each channel for protection

Product Information

Dimensions - See Figure 4 - 7

Wiring - See Figure 8

1. Connect to load
2. Bypass switch
3. Programming button & module indicator

Indicator flashes when device is in normal working mode. Press the button for 3 seconds, then the ID can be read and modified via HDL Buspro Setup Tool.

Safety Precautions

- The installation and testing for the product must be carried out by HDL Automation Co., Ltd. or its appointed service agencies. The electric construction shall comply with local laws and safety regulations.
- The device should be installed with DIN rail in DB box. HDL will not be responsible for any consequence caused by the inexpert or faulty installation and wiring methods, which are not in accordance with the instructions contained in this operating instruction.
- Please do not privately disassemble or replace any parts of the product. Otherwise, it may cause mechanical fault, electric shock, fire or personal injuries.
- Please contact our after-sales departments or our designated service agencies for your maintenance service. Product failures caused by private disassembly are not subject to this warranty.
- It is not allowed to exceed the range.

Package Contents

4(8/12)CH 16A High Power Switch Actuator (with Dry Contact) *1 / Buspro connector*1 / Label*5 / Datasheet*1

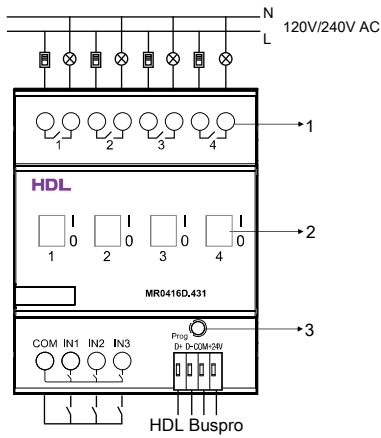

Take the connection of HDL-MR0416D.431 as an example
Figure 8. Wiring



↓ 1

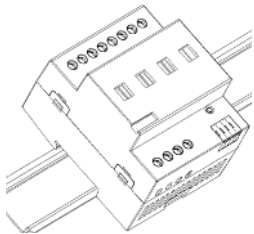

↓ 2

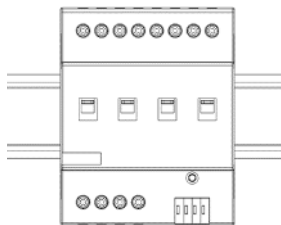

Figure 9. Installation

Technical Data

Basic Parameters

Working voltage	24~30V DC
Working current	40mA/24V DC
Input voltage	120V/240V AC (50/60Hz)
Output channel	HDL-MR0416D.431: 4CH, 16A/CH HDL-MR0816D.432: 8CH, 16A/CH HDL-MR1216D.433: 12CH, 16A/CH
Dry contact input	HDL-MR0416D.431: 3CH HDL-MR0816D.432: 4CH HDL-MR1216D.433: 4CH
Relay	50A Magnetic latching relay
Maximum current output of each channel	16A
Electronic life time of relay	>60000 (Resistive load)
Protection	Connect a breaker to each channel

External Environment

Working temperature	-5°C~45°C
Working relative humidity	≤90%
Storage temperature	-20°C~60°C
Storage relative humidity	≤93%

Specifications

Dimensions	HDL-MR0416D.431: 72mm×90mm×64mm HDL-MR0816D.432: 144mm×90mm×64mm HDL-MR1216D.433: 216mm×90mm×64mm
Net weight	HDL-MR0416D.431: 264g HDL-MR0816D.432: 487g HDL-MR1216D.433: 722g
Housing material	Nylon, PC
Installation	35mm DIN rail installation (See Figure 9)
Protection rating (Compliant with EN 60529)	IP20

Recommended Load Types and Power

240V, 16A, Resistive, 100,000 cycles, 40°C;
240V, 16FLA/96LRA, Motor, 30,000 cycles, 40°C;
240V, 16A, Standard Ballast, 30,000 cycles, 40°C;
240V, 16A, Electronic Ballast, 6,000 cycles, 40°C;
120V, 16FLA/96LRA, Motor, 30,000 cycles, 40°C;
120V, 16A, Electronic Ballast, 6,000 cycles, 40°C;
120V, 16A, Standard Ballast, 30,000 cycles, 40°C;

Approved

CE

RoHS

HDL Buspro Cable Guide

HDL Buspro	HDL Buspro Cable	CAT5/CAT5E
DATA+	Yellow	Blue/Green
DATA-	White	Blue white/Green white
COM	Black	Brown white/Orange white
24V DC	Red	Brown/Orange

Installation

Installation - See Figure 9 (Take HDL-MR0416D.431 as an example)

- Step 1. Fix the DIN rail with screws.
- Step 2. Buckle the bottom cap of the actuator on the edge of the DIN rail.
- Step 3. Press the device on the DIN rail, slide it and fix it up until an appropriate position is adjusted.

Technical support

E-mail: hdltickets@hdlautomation.com
Website: <https://www.hdlautomation.com>

©Copyright by HDL Automation Co., Ltd. All rights reserved.
Specifications subject to change without notice.