

DataPoint™ LC52

Continuous Level Sensor Controller



Application

The general purpose AC powered tank or silo level controller displays engineering units with one 4-20 mA level transmitter, two programmable relays and an isolated 4-20 mA repeater. Relay one is configurable on a single set point. Relay two can be configured on a single set point or latched on two set points for automatic fill or empty control in simplex mode. Select this DIN rail mount controller for use with general purpose two or three-wire level sensors. For field mount installation, add a single or double NEMA box with optional flash and/or audible alarm.



LC52-1001
Shown

Features

- Bright LED display indicates level in custom engineering units
- Fail-safe relay control of pumps or valves with 0-60 second delay
- Easy push button configuration of span, display and relay set points
- 35mm DIN rail mount PP enclosure with removable terminal strips
- Invert switch changes relay state from NO to NC without rewiring
- Bar graph display indicates the percentage of measured span
- Available with custom NEMA boxes and tank alarm accessories

Key Benefits

- Controls pumps, valves, horns and alarm indicators
- Complete solution for level sensor control requirements
- Lock-out feature prevents unauthorized setting changes
- 35mm DIN rail or screw mount design for easy installation

Compatible Products



ECHOWAVE®
Guided Wave Level
Transmitter



ECHOPOD®
Ultrasonic Level
Transmitter



ECHOSONIC®
Ultrasonic Level
Transmitter



ECHOPOD®
Ultrasonic Level
Transmitter



ECHOPULSE®
Pulse Radar Level
Transmitter

DataPoint™ LC52

Continuous Level Sensor Controller



Specifications

Display type:	LED, 3.5 digit
Display units:	Engineering
Display output:	0 to 999
LED indication:	Power & relay
LED bar graph:	Span & set points
Memory:	Non-volatile
Security:	Set point lock out
Configuration:	Push button
Alarm indication:	Amber: < 4mA Red: > 20mA
Sensor input:	(1) 4-20mA
Supply voltage:	120 / 240 VAC @ 50-60 Hz.
Sensor supply:	24 VDC @ 1.5 watts
Loop power:	4-20mA, 18 VDC
Consumption:	5 watts maximum
Contact type:	(2) SPDT relay (1 latching)
Contact rating:	250 VAC @ 10A
Contact output:	Selectable NO / NC
Contact latch:	Selectable ON / OFF
Contact delay:	0.15 - 60 seconds
Repeater output:	4-20mA, 12-36 VDC
Ambient temp.:	F: -40° to 158° C: -40° to 70°
Pressure:	Atmospheric
Enclosure type:	35mm DIN rail (EN 50 022)
Encl. material:	PP, UL94VO
Classification:	General purpose

Dimensions

Top View

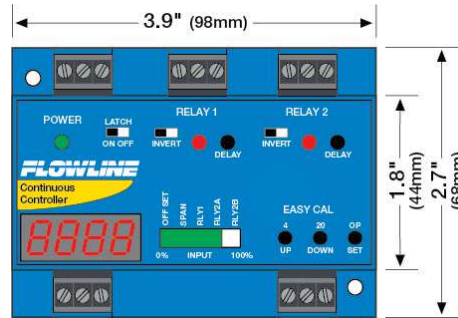

Side View

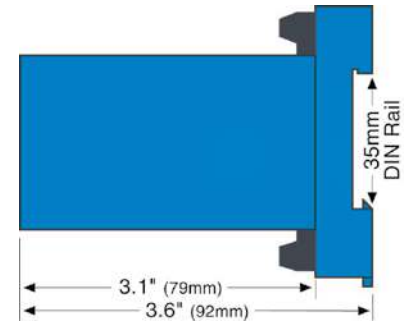

Accessories

Protect your level controller from the elements using the below single or double NEMA boxes that come with 35mm DIN rail mounting hardware.

P/N	DESCRIPTION
 LM92-1202	Single NEMA box, windowed, 35mm rail, PC
 LM92-2202	Double NEMA box, windowed, 35mm rail, PC

Ordering

LC52-1001 (1)

NOTES

- 1) For field mount installation in a NEMA 4X polycarbonate enclosure, order the single or double NEMA box.