

**BODY**

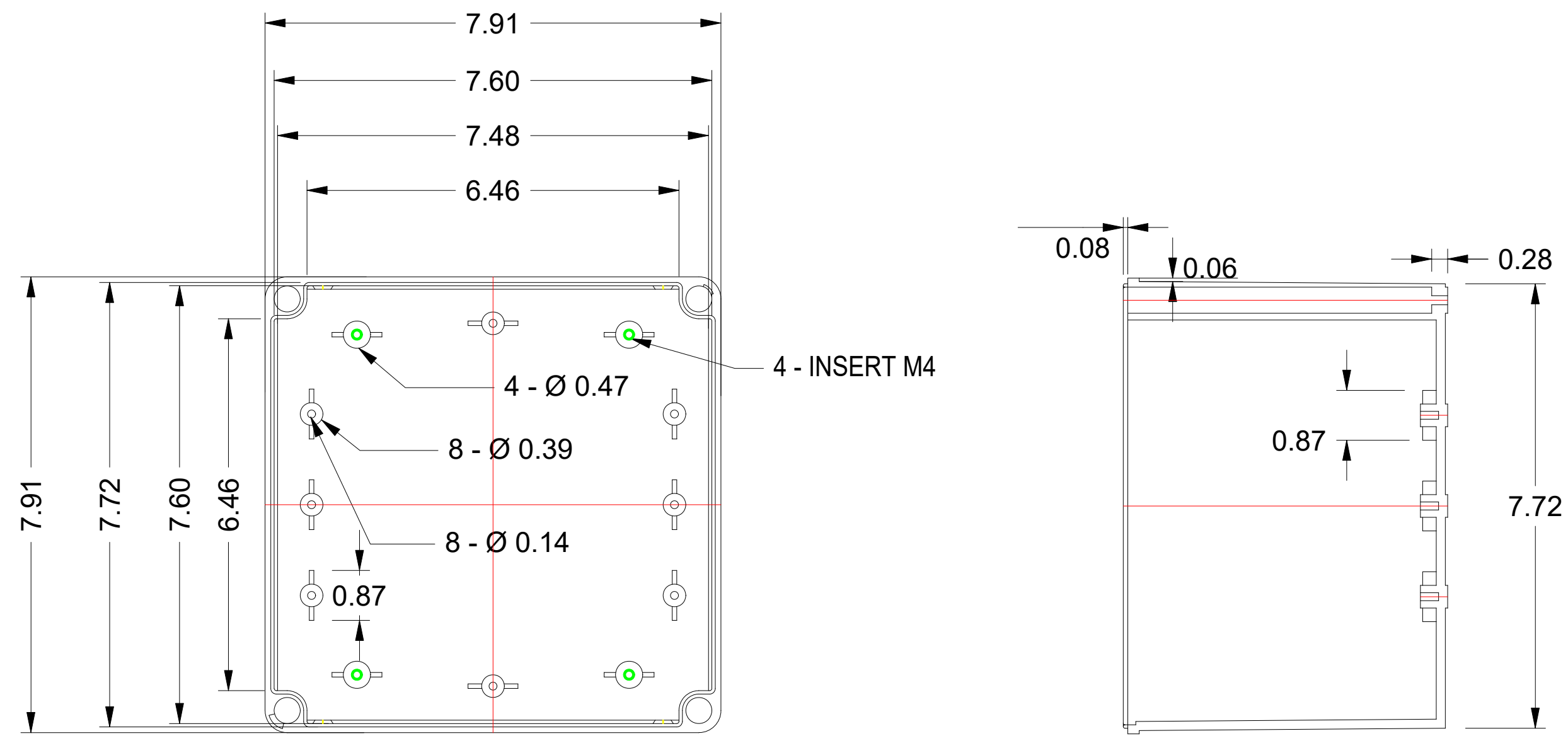

**COVER**

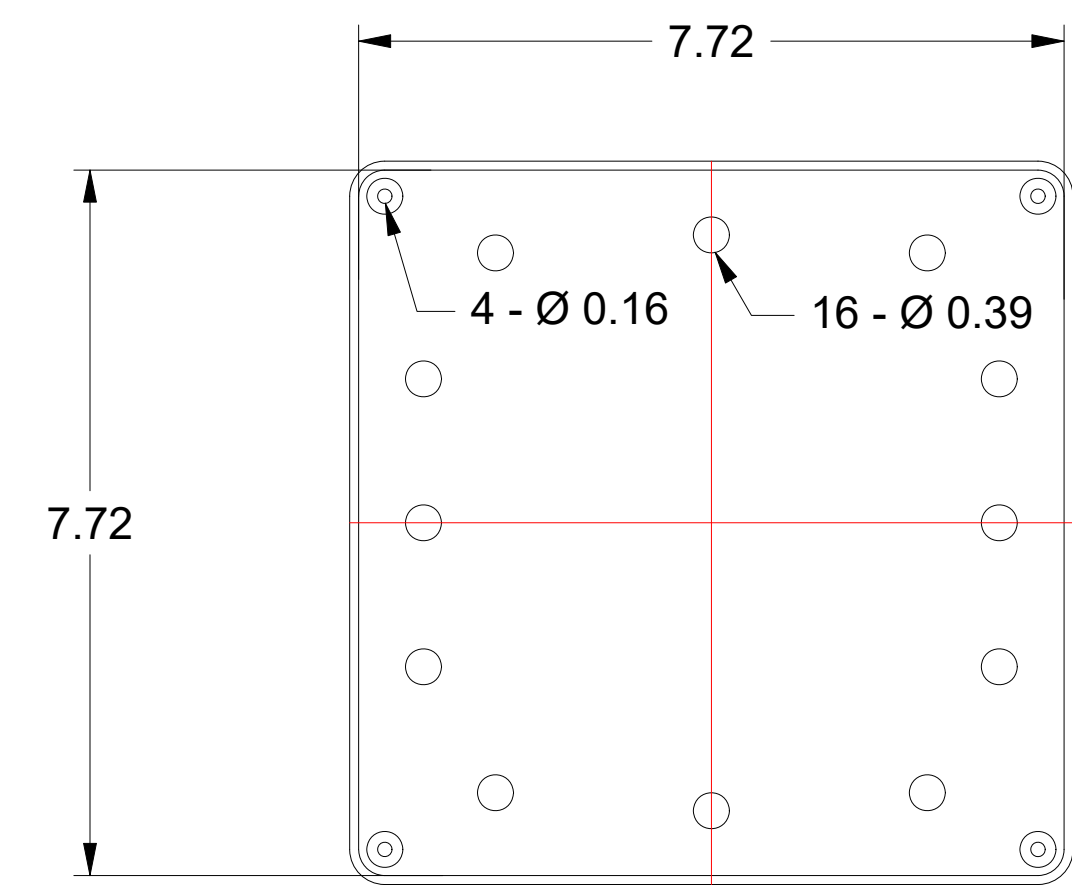
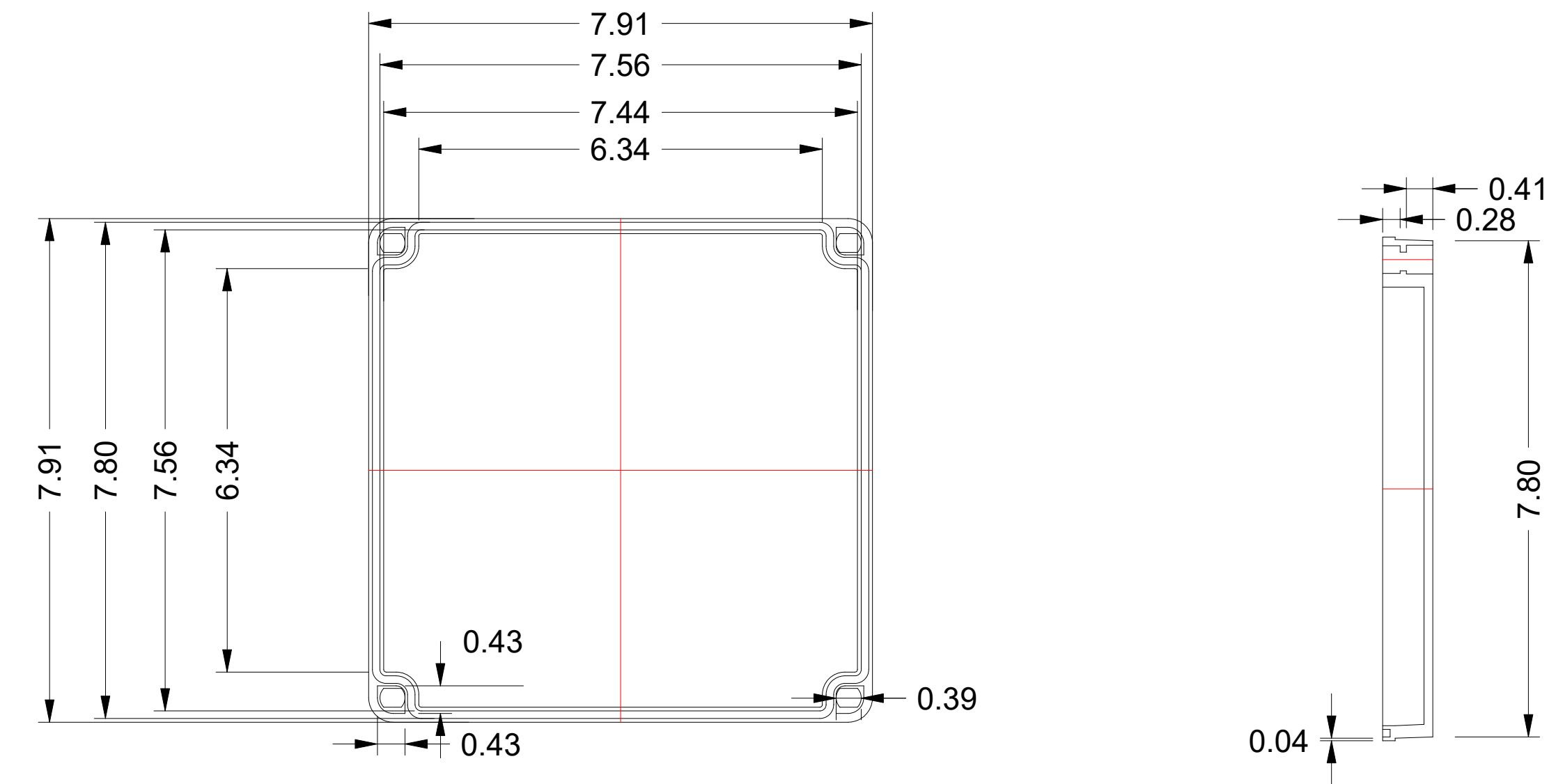

**BOTTOM VIEW**

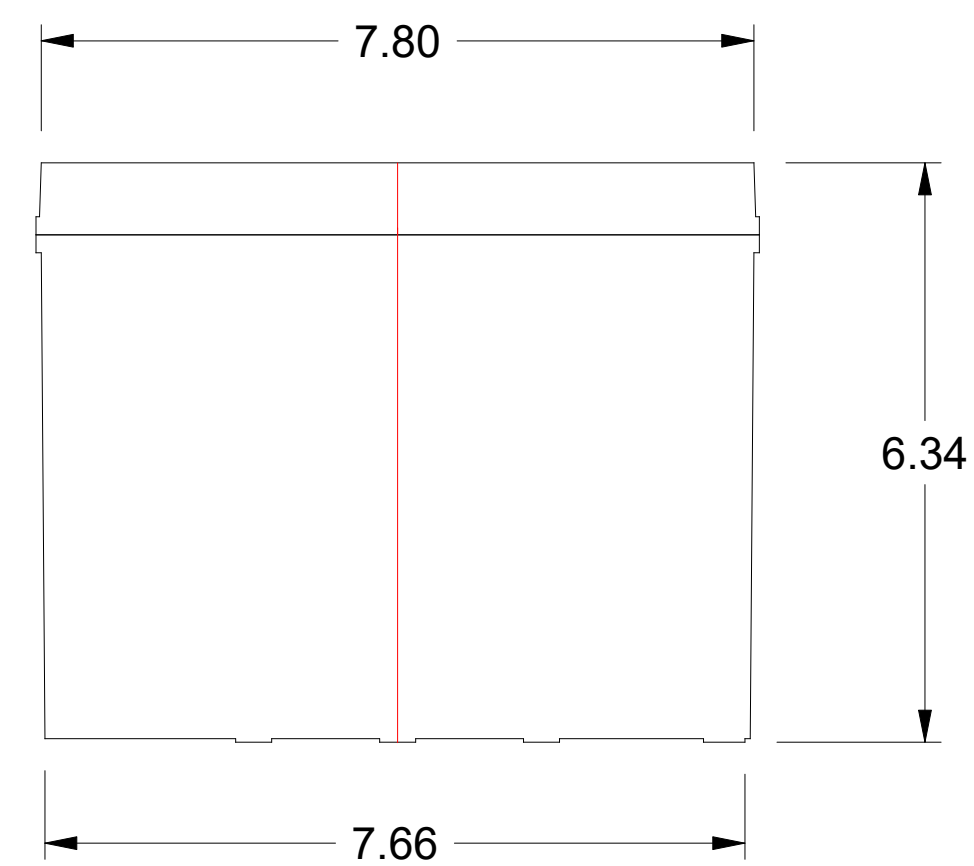

**ASSEMBLED SIDE VIEW**

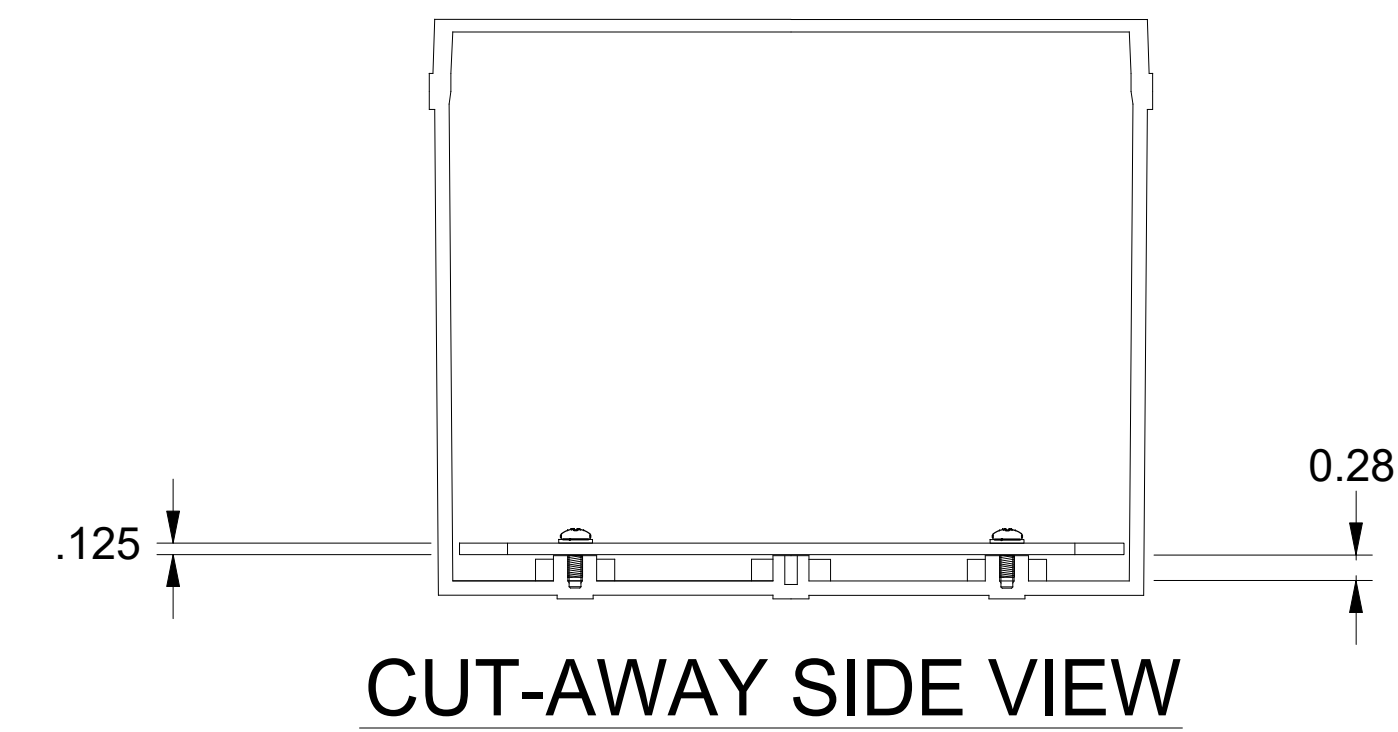

**CUT-AWAY SIDE VIEW**

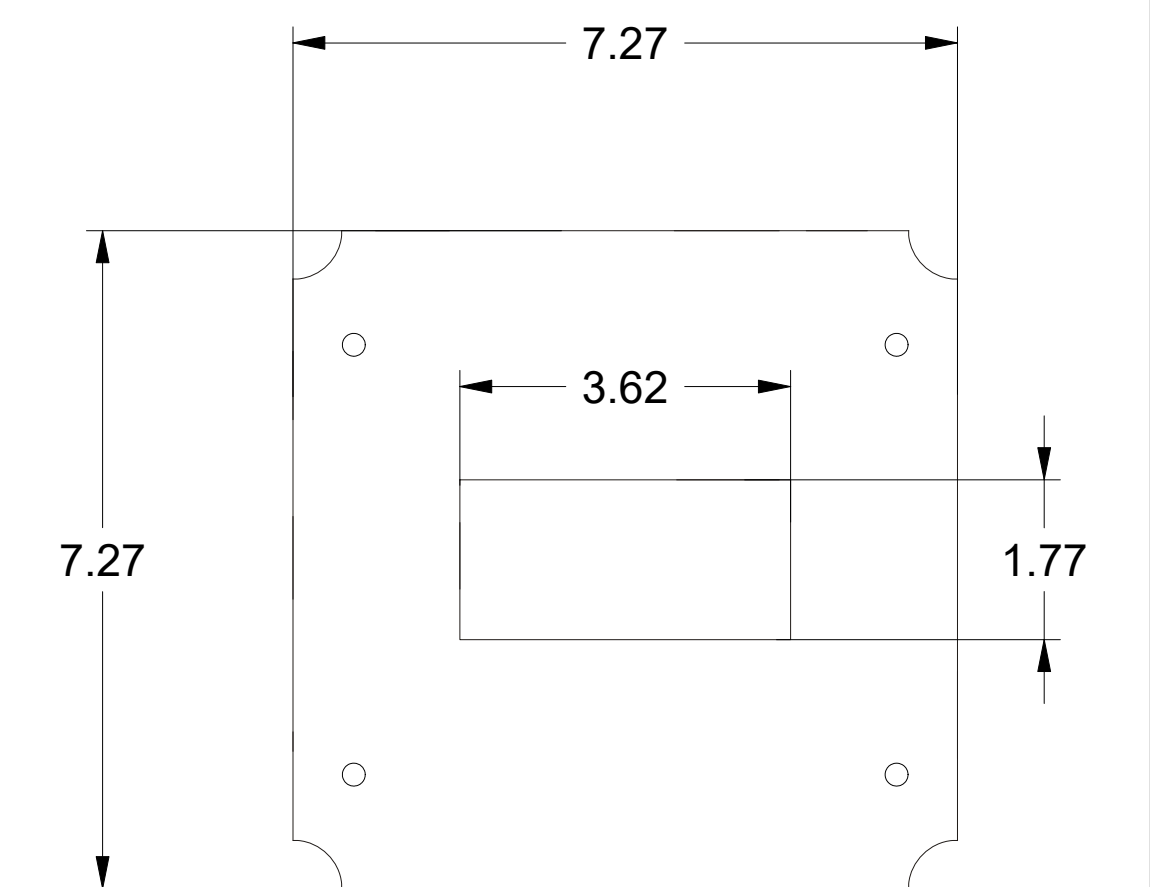

**MOUNTING PLATE**

#8-32 1/2" PHILLIPS  #8 WASHER 

**HARDWARE**

NOTES: ALL DIMENSIONS SHOWN ARE IN INCHES.

DRAWN  
P. Colin  
02/01/2016

**FLOWLINE INC.**

LOS ALAMITOS, CA 90720

**LM92-1202 ENCLOSURE  
DRAWING FILE  
301685 REV A**

SCALE 1:2 | SIZE D (34 x 22) | SHEET 1 OF 1