

EchoPro[®] LR11

Pulse Radar Liquid Level Transmitter



Application

The intrinsically safe 26 GHz. pulse radar level transmitter provides continuous level measurement up to 32.8' (10m) with a 4-20 mA analog and HART digital signal output, and is configured via its integral push button display module or HART communicator. The non-contact liquid level sensor is intended for chemical or water storage applications in above grade metal or reinforced concrete tanks or below grade tanks of any material. Select this sensor for **easy process conditions with corrosive media**, light agitation, condensation or vapor, and installation in a low-profile tank adapter or flange fitting. Typical applications include chemical bulk storage and tanker trucks.



Features

- PFA encapsulated antenna and mount for corrosive media
- Configuration via push button display or HART communicator
- 26 GHz. pulse radar is unaffected by vapor or condensation
- 12" (30cm) dead band enables utilization of the entire tank
- LCD displays level in feet or meters with percent of span bar
- Optional display mode indicates the echo signal return curve
- Fail-safe diagnostics with selectable signal fail-safe outputs
- Recognition, storage and rejection of false echo signal returns
- IP67 stainless enclosure with polycarbonate display window

Corrosion Resistance

The US produces 40 million tons of sulfuric acid per year that is widely used in oil refining, wastewater treatment, lead-acid battery and cleaning product applications. In higher concentrations, sulfuric acid is both extremely corrosive and vaporous. The non-contact LR11 sensor is an excellent choice for this application, as its 26 GHz. pulse radar measurement is unaffected by vapor, and the antenna and process mount are encapsulated in corrosion resistant PFA for years of reliable service. Select this sensor with confidence in corrosive, vaporous applications.



LR11-5421-00
Shown



Push Button
Display Module

EchoPro[®] LR11

Pulse Radar Liquid Level Transmitter



Specifications

Range:	12" to 32.8' (30cm to 10m)
Frequency:	26 GHz.
Accuracy:	± 5mm
Dead band:	12" (30cm)
Beam angle:	22°
Configuration:	Push button, HART 7
Memory:	Non-volatile
Display type:	LCD, dot matrix
Display units:	Feet and meters
Display bar:	Percent of span
Display graph:	Echo signal curve
Supply voltage:	21.6 to 26.4 VDC
Max. consumption:	22.5 mA
Signal output:	4-20 mA, two-wire, HART 7
Signal invert:	4-20 mA, 20-4 mA
Signal fail-safe:	3.9 mA, 20.5 mA, 22 mA
Process temp.:	F: -40° to 266° C: -40° to 130°
Temp. comp.:	Automatic
Storage temp.:	F: -40° to 176° C: -40° to 80°
Pressure:	-14.5 to 43.5 psi (-1 to 3 bar)
Enclosure rating:	IP67
Encl. material:	316L stainless steel w/silicone gasket and PBT FR neck
Encl. window mat.:	Polycarbonate
Conduit entrance:	(1) 1/2" NPT connector
Antenna material:	PFA
Process mount:	1-1/2" NPT
Classification:	Intrinsically safe
Approvals:	ATEX IIG Ex ia II C T6...T3 Ga IEC Ex ia IIC T6...T3 Ga CSA Class I, Div 1, Groups A, B, C & D; Class II, Div 1, Groups E, F & G; (T6... T3); Class I Zone 0 AEx ia IIC (T6... T3) Ga & Zone 20 AEx ia IIC (T76°C to T146°C) Da; Ex ia IIC (T6...T3) Ga & Ex ia IIC (T76°C to T146°C) Ga
Certification:	FCC
Compliance:	CE, RoHS

Level Indicator



LI24-1001

DATALOOP[™]

Intrinsically Safe Level Indicator

UL approved intrinsically safe, the loop powered level indicator displays engineering units connected in series with one 4-20 mA level transmitter. Select the LI24-1001 level indicator for hazardous applications with an intrinsically safe sensor. For field mount installation, add a single or two indicator NEMA box.

Dimensions

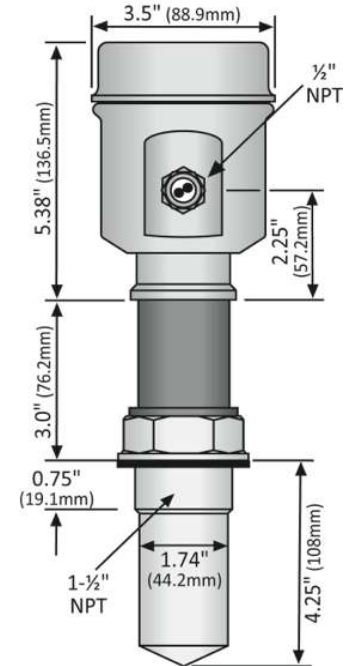

Fittings

REDUCER BUSHINGS

LM53-2400

2" x 1.5" NPT, PVC, schedule 40

LM53-2800

2" x 1.5" NPT, PVC, schedule 80

LM53-3800

3" x 1.5" NPT, PVC, schedule 80



LM53-3800



LM53-2800

ANSI FLANGES

LM53-3850

3" x 1.5" NPT, CPVC, schedule 80

LM53-4850

4" x 1.5" NPT, CPVC, schedule 80

LM53-6850

6" x 1.5" NPT, CPVC, schedule 80



LM53-3850

Ordering

LR11-5421-00

(1) (2)

NOTES

- 1) If you want help in selecting a sensor for your application, please go to our website and submit a Level Questionnaire. An engineer will review your requirements and suggest a product solution via email.
- 2) Install the sensor using Flowline installation fittings or equivalents.