

# Smart Trak™ AX23

with Compact Level Controller



## Application

The general purpose level switch package provides automatic tank filling or emptying up to 10' (3m) between two adjustable level switch points. The compact relay controller with optional strobe provides one latching 16A relay for pump or valve control. Offered in three sensor technologies, choose the type based upon your application media. This PP level switch package is selected for day tank, skid or machine, cooling tower, waste sump and process tank applications, requiring detection and control.



## Features

- Fail-safe relay control of pumps or valves with adjustable time delay
- Offered in three sensor technologies for broad application coverage
- Easy setup with LED indicators for sensor, power and relay status
- Rugged polypropylene construction for use with corrosive liquids
- Adjustable switch cars enable sensor position adjustments in the field
- Invert switch changes relay state from NO to NC without rewiring



AV23-4213 Shown

## Key Benefits

- Complete solution to automatically fill or empty a tank between two switch points with full pump or valve control - just add power
- Sensor positions are easily adjusted enabling fine tuning of the level switch points in the field

## Sensor Technologies



LU10

### SWITCH-TEK™

#### Ultrasonic Level Switch

Broadly applied in chemicals and light weight oils



LZ12

### SWITCH-TEK™

#### Vibration Level Switch

Applied in wastewater with light coating or scaling



LV10

### SWITCH-TEK™

#### Vertical Buoyancy Level Switch

Applied in clean water and non-coating chemicals

# Smart Trak™ AX23

with Compact Level Controller



## Specifications

<b>Length:</b>	8" to 10' (20cm to 3m)
<b>Accuracy:</b>	± 1mm in water
<b>Repeatability:</b>	± 0.5mm in water
<b>Orientation:</b>	± 20° vertical
<b>Switch points:</b>	2 (field adjustable)
<b>LED indication:</b>	Power, relay & sensor
<b>Supply voltage:</b>	120 / 240 VAC @ 50-60 Hz
<b>Consumption:</b>	0.25A maximum
<b>Strobe type:</b>	-431X: N/A -432X: Xenon tube
<b>Strobe flash:</b>	-431X: N/A -432X: 1 per second
<b>Contact type:</b>	(1) SPDT relay, latching
<b>Contact rating:</b>	250 VAC @ 16A
<b>Contact output:</b>	Selectable NO / NC
<b>Contact delay:</b>	0.15 - 60 seconds
<b>Contact latch:</b>	Selectable ON / OFF
<b>Process temp.:</b>	F: -40° to 176° C: -40° to 80°
<b>Ambient temp.:</b>	F: -40° to 140° C: -40° to 60°
<b>Installed height:</b>	-431_: 5.7" (14.4 cm) -432_: 7.4" (18.8 cm)
<b>Pressure:</b>	Atmospheric
<b>Enclosure rating:</b>	NEMA 4X (IP65)
<b>Enclosure mat.:</b>	-432X: PP, UL94VO & PC -431X: PP, UL94VO
<b>Conduit entrance:</b>	1/2" NPT
<b>Wetted material:</b>	PP (20% glass fill)
<b>Process mount:</b>	2" NPT (2" G)
<b>Classification:</b>	General purpose
<b>Compliance:</b>	CE

## Dimensions

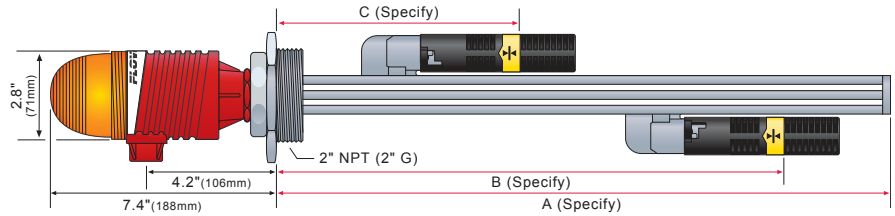

## Fittings

For optimum performance, install Smart Trak™ using the below recommended or direct equivalent fittings.

	P/N	DESCRIPTION
	<b>LM52-2400</b>	3" NPT x 2" NPT, PVC, schedule 40
	<b>LM52-2800</b>	3" NPT x 2" NPT, PVC, schedule 80
	<b>LM52-3800</b>	4" NPT x 2" NPT, PVC, schedule 80
	<b>LM52-2410</b>	3" socket x 2" NPT, PVC, schedule 40
	<b>LM52-3410</b>	4" socket x 2" NPT, PVC, schedule 40
	<b>LM52-2810</b>	3" socket x 2" NPT, PVC, schedule 80
	<b>LM52-3810</b>	4" socket x 2" NPT, PVC, schedule 80
	<b>LM52-2890</b>	2" NPT bulkhead, PVC
	<b>LM52-2850</b>	2" ANSI x 2" NPT, PVC, schedule 80
	<b>LM50-1001</b>	2" NPT side mount bracket, PP

## Ordering

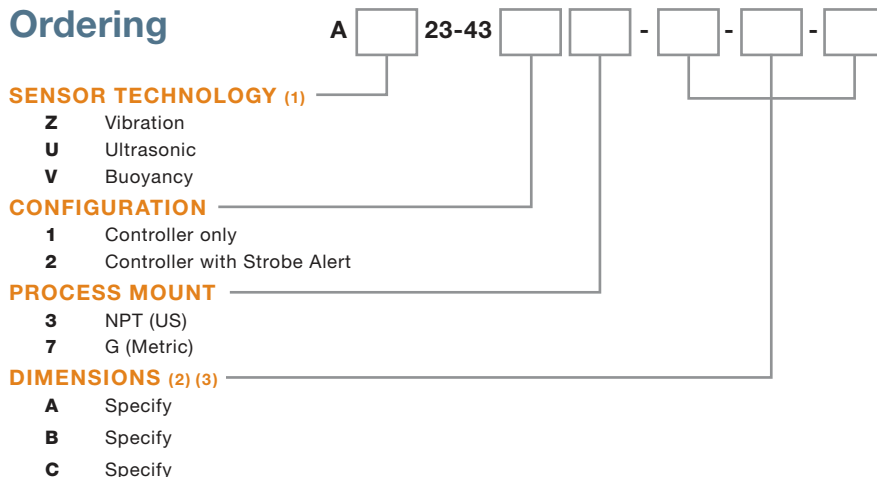

## NOTES

- 1) Select the best level sensor technology based upon your application.
- 2) Specify the A, B, C dimensions at the end of the part number (ie: AZ23-4343-87"-76"-17"). The dimensions may be specified in 1/2" (1.3cm) increments. The track length or A-dimension may be specified from 12" to 10' (20cm to 3m). The sensor or B and C dimensions may be specified from 4" to 10' (10cm to 3m). For maximum field adjustability, specify all sensor dimensions equal to the A-dimension.
- 3) To calculate the track length adder, round up the A-dimension to the next foot (30 cm) and add \$20 per foot (30cm) to the price.