

EchoPod® UG06 & UG12

Reflective Ultrasonic Liquid Level Transmitter



Application

The general purpose reflective ultrasonic level transmitter provides continuous level measurement up to 39.3' (12m) with a 4-20 mA analog signal output, and is configured via its integral push button display module or WebCal software. The non-contact liquid level sensor features our proprietary Reflective Technology™ that delivers reliable level measurement in condensing environments. Select this sensor for bulk tanks with non-foaming or mildly vaporous media such as chemicals, water, wastewater and oil. Typical applications include bulk storage, neutralization tank, clarifier and waste sumps.



Features

- Offered in 6m (19.6") and 12m (39.3') measurement ranges
- Reflective Technology™ measures reliably with condensation
- Corrosion resistant PVDF transducer with IP68 PP enclosure
- Fail-safe diagnostics with selectable signal fail-safe outputs
- LCD display indicates level in inches, meters or percent of span
- Narrow 3" (7.6cm) beam width for applications with limited space
- Windowed enclosure cap provides liquid tight level indication
- Configuration via push button display or WebCal software
- Automatic temperature compensation from -40° to 80° C.

Reflective Technology™

Condensation is the most common variable in liquid level applications. Condensation attenuates the acoustic signal of ultrasonic sensors with horizontal transducers, weakening their signal strength and signal to noise ratio by up to 50%, and substantially reducing their measurement reliability. At the core of Reflective Technology™ is a simple fact. Unlike flat horizontal surfaces, significant water droplets cannot adhere to smooth vertical surfaces. By orienting the transducer vertically, condensation runs off the transducer and does not affect sensor performance. The unimpeded transmit and receive signals are redirected to and from the liquid off a 45° reflector, delivering reliable level measurement. Thanks gravity.



UG12 Shown

UG06 Shown



Horizontal Transducer

Reflective Transducer

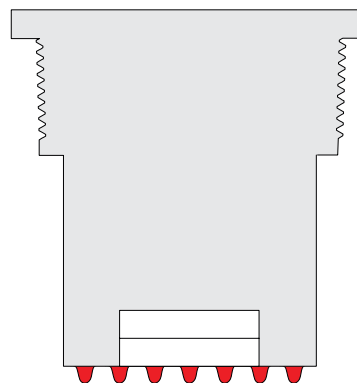

Signal Attenuation

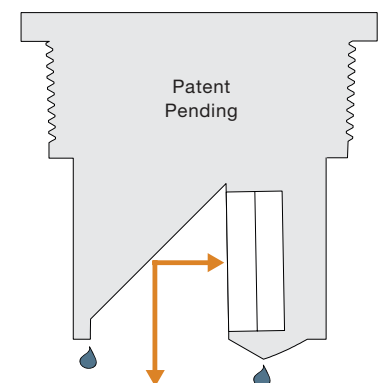

Reliable Measurement

EchoPod® UG06 & UG12

Reflective Ultrasonic Liquid Level Transmitter



Specifications

Range:	UG06: 8" to 19.6' (20cm to 6m) UG12: 18" to 39.3' (45.7cm to 12m)
Accuracy:	± 0.2% of range
Resolution:	UG06: 0.079" (2mm) UG12: 0.196" (5mm)
Dead band:	UG06: 8" (20.3cm) UG12: 18" (45.7cm)
Beam width:	UG06: 3" (7.6cm) UG12: 6" (15.2cm)
Configuration:	Push button or WebCal® PC Windows® USB® 2.0
Memory:	Non-volatile
Display type:	LCD, 6-digit
Display units:	Inch, cm or percent
Supply voltage:	14-28 VDC
Max. consumption:	0.5W
Loop resistance:	500 ohms @ 24 VDC
Signal output:	4-20mA, two-wire
Signal invert:	4-20mA or 20-4mA
Signal fail-safe:	4mA, 20mA, 21mA, 22mA, hold last
Process temp.:	F: -40° to 176° C: -40° to 80°
Temp. comp.:	Automatic
Ambient temp.:	F: -31° to 140° C: -35° to 60°
Pressure:	30 psi (2 bar)
Enclosure rating:	Type 6P (IP68)
Encl. material:	Polypropylene
Encl. cap material:	Clear polycarbonate
Enclosure vent:	Water tight membrane
Conduit entrance:	1/2" NPT
Transducer type:	Reflective
Transducer mat.:	Polyvinylidene fluoride
Process mount:	06-0001: 2" NPT 06-0011: 2" G 12-0001: 3" NPT 12-0011: 3" G
Mount gasket:	-0001: N/a -0011: Viton®
Classification:	General purpose
Approval:	UL 61010-1
Compliance:	CE, RoHS

Dimensions

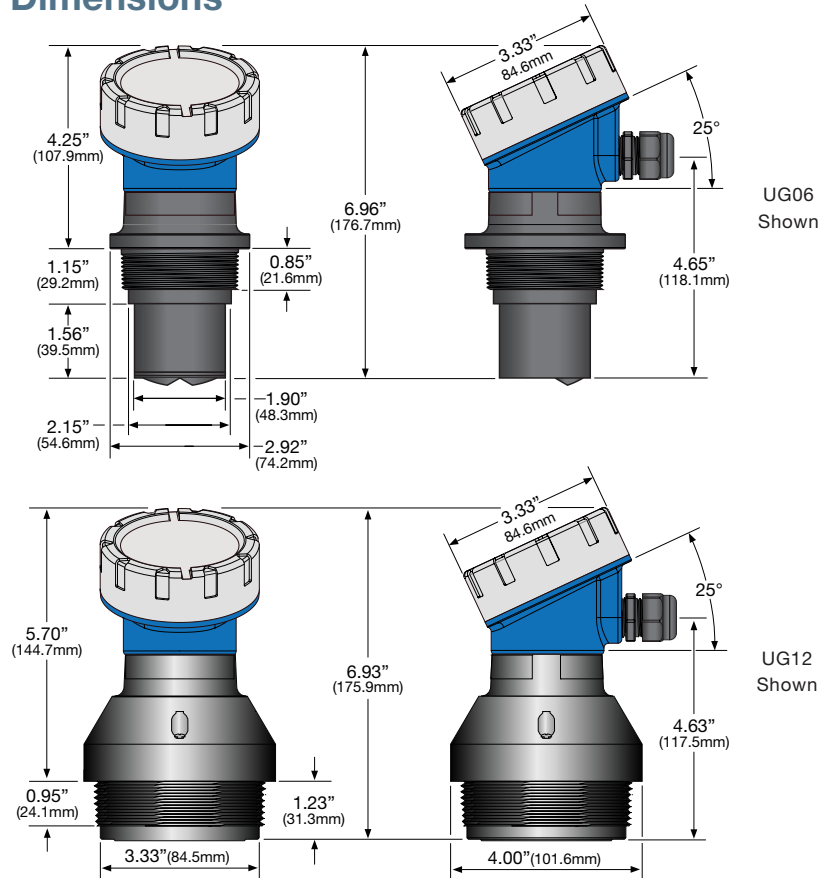

Configuration

In addition to the push button display module, the sensor may be configured via our WebCal software and one Fob USB adapter. WebCal is a PC utility program that allows users to easily configure their sensors, update firmware, save configurations and print wiring schematics prior to installation. WebCal is a free download from our website.



Ordering

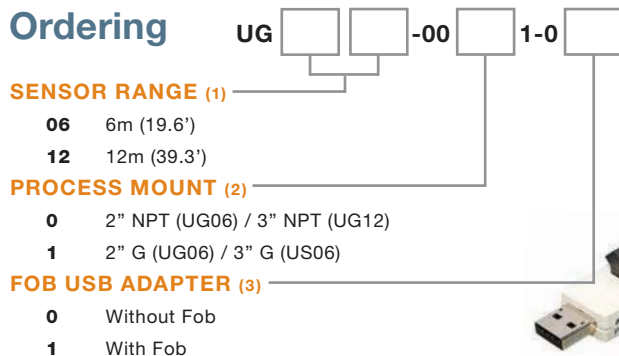

NOTES

- 1) If you want help in selecting a sensor for your application, please go to our website and submit a Level Questionnaire. An engineer will review your requirements and suggest a product solution via email.
- 2) Install the sensor using Flowline installation fittings or equivalents.
- 3) Sensors are offered with or without a LI99-2001 Fob USB adapter. If you want to configure the sensor using our free WebCal software, you need one Fob, which can then be used with any WebCal compatible ultrasonic or guided wave sensor. WebCal is a free download from our website.