

# EchoPod® DL10

Ultrasonic Liquid Level Transmitter



## Application

The general purpose ultrasonic transmitter provides continuous level measurement up to 49.2" (1.25m) with a 4-20 mA signal output, and is configured via our free WebCal® software. This non-contact liquid level sensor is ideally suited for corrosive, sticky or waste liquids, and is selected for chemical feed, IBC or drum, skid or machine and cooling tower applications.



## Features

- Continuous non-contact level measurement up to 49.2" (1.25m)
- 4-20 mA output for longer signal distances up to 1000' (300m)
- Configuration is fast and easy via WebCal software and USB adapter
- Narrow 2" beam width and short 2" dead band optimized for small tanks
- PVDF transducer and 6P polycarbonate enclosure for corrosive liquids
- Automatic temperature compensation for accurate measurement

## Success

Stormwater run-off from highways is a major source of pollution that degrades our clean water resources, negatively impacting both wildlife and people. This run-off carries high levels of lead, fuel, oil and chemicals which are commonly found on highways. State and federal agencies monitor run-off to determine its volume, content and risk to the local environment. Here, an EchoPod ultrasonic level sensor is installed over a V-Notch weir on the side of the highway. The continuous level sensor measures the volume of stormwater passing through the weir, and provides a 4-20 mA signal to the wireless telemetry system for remote data collection.



## Compatible Products



**LI23**  
**DATALOOP™**  
Level Indicator



**LI55**  
**DATAVIEW™**  
Level Controller



**LI40**  
**PODVIEW™**  
Level Indicator

# EchoPod® DL10

Ultrasonic Liquid Level Transmitter



## Specifications

<b>Range:</b>	49.2" (1.25m)
<b>Accuracy:</b>	0.125" (3mm)
<b>Resolution:</b>	0.019" (0.5mm)
<b>Dead band:</b>	2" (5cm)
<b>Beam width:</b>	2" (5cm)
<b>Configuration:</b>	WebCal® PC Windows® USB 2.0
<b>Memory:</b>	Non-volatile
<b>Supply voltage:</b>	24 VDC (loop)
<b>Consumption:</b>	0.5W
<b>Loop resist.:</b>	400Ω max @ 24 VDC
<b>Signal output:</b>	4-20 mA, two-wire
<b>Signal invert:</b>	4-20 mA or 20-4 mA
<b>Loop fail-safe:</b>	4 mA, 20 mA, 21 mA, 22 mA or hold last
<b>Process temp.:</b>	F: 20° to 140° C: -7° to 60°
<b>Temp. comp.:</b>	Automatic
<b>Ambient temp.:</b>	F: -31° to 140° C: -35° to 60°
<b>Pressure:</b>	MWP = 30 PSI (2 bar)
<b>Enclosure rating:</b>	Type 6P, encapsulated, corrosion resistant & submersible
<b>Encl. material:</b>	Polycarbonate
<b>Strain relief mat.:</b>	Santoprene
<b>Trans. material:</b>	PVDF
<b>Cable jacket mat.:</b>	Polyurethane
<b>Cable type:</b>	4-conductor, shielded
<b>Cable length:</b>	48" (1.2m)
<b>Process mount:</b>	1" NPT (1" G)
<b>Mount gasket:</b>	Viton®
<b>Classification:</b>	General purpose
<b>Compliance:</b>	CE, RoHS
<b>Approvals:</b>	cFMus

## Dimensions

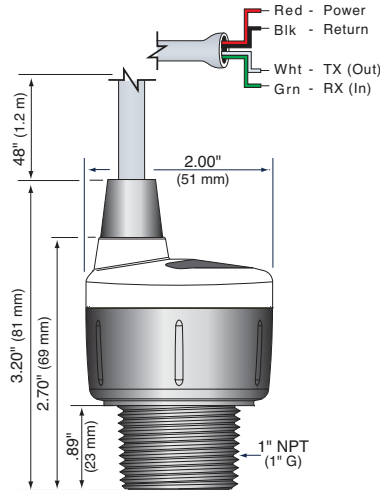

## Configuration



The level sensor is configurable via our free WebCal PC software and Fob USB adapter. The sensors are offered with and without Fobs. Fobs are universal and can be used to configure any WebCal compatible product. Download your free copy of WebCal in English or Chinese.

## Fittings

For optimum performance, install the level sensor using the below recommended or direct equivalent fittings.

	P/N	DESCRIPTION
	<b>LM52-1400</b>	2" NPT x 1" NPT, PVC, schedule 40
	<b>LM52-1800</b>	2" NPT x 1" NPT, PVC, schedule 80
	<b>LM52-1410</b>	2" socket x 1" NPT, PVC, schedule 40
	<b>LM52-1810</b>	2" socket x 1" NPT, PVC, schedule 80
	<b>LM52-1850</b>	1" ANSI x 1" NPT, CPVC, schedule 80
	<b>LM50-1001-1</b>	1" NPT side mount bracket, PP

## Ordering

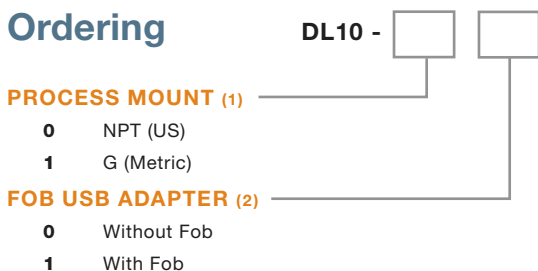

## NOTES

- 1) Install the level sensor using Flowline installation fittings or equivalents.
- 2) The level sensor is configured via our WebCal software and one LI99-1001 Fob USB adapter. The level sensor is offered with and without a Fob. Fobs are universal and can be used to configure any WebCal compatible product. WebCal is a free download from our website.