

## Parameters

Electrical Parameters:	
Input voltage	AC85-265V , 50/60Hz
Output current	8A
Power consumption	0.45W max.
Wireless transmit power	+10dbm
Wireless receive sensitivity	-90dbm
Indoor communication distance	<=30m
RSSI receive signal receiving	>-80dbm
Wireless central frequency	
WPAN (China)	780 to 786MHz
SRD (Europe)	864 to 870MHz
ISM (North America)	904 to 928MHz
Default band	780 MHz
Default PSK	HDL-SecurityKey0
Environment Conditions:	
Working temperature	-5°C~45°C
Working relative humidity	<90%
Storage temperature	-20°C~+60°C
Storage relative humidity	<93%
Approved	
CE	
RoHS	
Product Information:	
Dimensions	44x36x17 (mm)
Weight	39.7g
Housing material	PC
Installation	Wall box
Protection degree	IP20
Fire and null wire	1.5mm <sup>2</sup> (the module provides 15cm wire)
Load cable	1.5mm <sup>2</sup> (the module provides 15cm wire)
Stripping length	5~7mm

## Important Notes

- This module should work with wireless gateway
- Connection - Check the connection, avoid short circuit
- When power on, cannot touch the power, load and dry contact terminal, avoid the electric shock
- The subnet ID of wireless relay should be same as the wireless gateway

## Overview



HDL-MPR02-RF.18 wireless 2CH relay, has 4CH dry contact, can control target by switch. This module should work in conjunction with wireless gateway

## Functions

- 2CH relay output
- Support switch on delay, protection delay, switch off delay
- The 4CH dry contact supports: mechanical switch and electronic switch, can control the target, has dimming function
- The dry contact supports: mechanical switch, single on, single off, single on/off, combination on/off, multi-Function, parallel switch
- Each switch type can set switch mode, dimmable two-way, dimmable increase, dimmable reduce.
- Control type: scene, sequence, universal switch, single channel lighting control, broadcast scene, broadcast channel, curtain switch, GPRS control switch, panel control, security module, z-audio control
- Support IEEE.802.15.4
- Support online upgrading
- Support easy programming

## Dimensions and Wiring

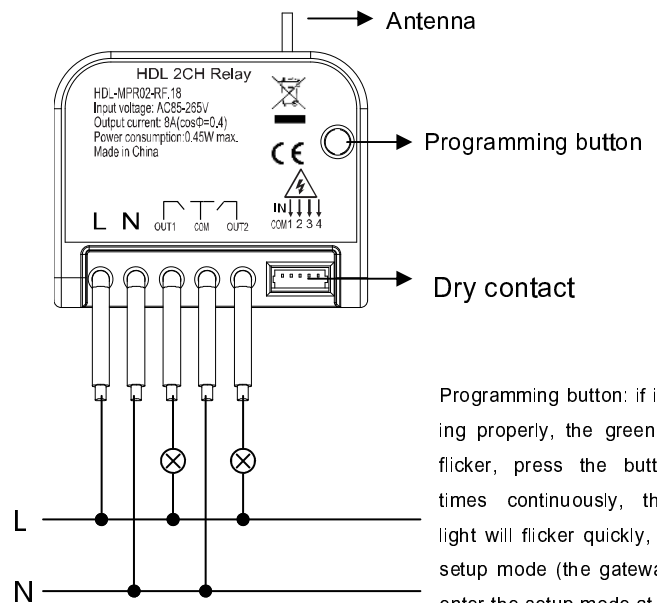
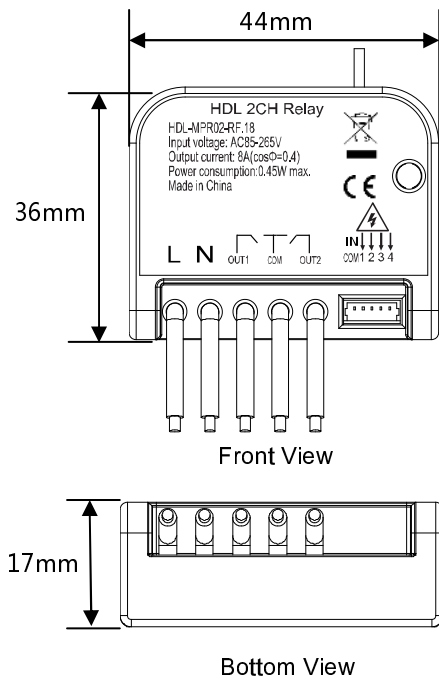

Programming button: if it is working properly, the green light will flicker, press the button three times continuously, the green light will flicker quickly, enter the setup mode (the gateway should enter the setup mode at the same time, and then, set the parameter)

## Safety Precautions

- When power on, cannot touch the power, load, dry contact terminal, avoid electric shock.
- Never let the liquids get into the module, it will damage this device.
- Ensure good ventilation
- Output channel - The following list is the recommended for output channel. To protect the relay, please connect a 16A breaker for each channel.

### ■ Recommended load type and power (work in AC220V)

motors:	1HP ( 1HP=746W )
Incandescent lamp load:	3500W
Inductive transformer:	450 W
Electronic transformer:	500W
Halogen lamp:	3500 W
Mercury vapor lamp	
*Uncompensated lamp:	700 W
*Parallel compensated lamp:	700 W
Fluorescent lampT5 / T8	
*Uncompensated lamp:	875 W
* Parallel compensated lamp:	500W
*DUO lamp:	500W
Dulux lamp	
*Uncompensated lamp:	375 W
*Parallel compensated lamp:	375W

## Packing List

- HDL-MPR02-RF.18\*1 / Datasheet\*1