

TFA-17 series of air quality monitor for atmospheric environment and underground facilities

- *Over 12-year experience in IAQ product design and production, long-term export to Europe and America, powerful strength guaranteed.*
- *Built in commercial high precision sensor module, accurate measurement parameters, extremely cost-effective.*
- *Design of high temperature resistant shell, wider range of temperature and humidity adaptability*
- *Suitable for air quality monitoring in harsh environment, which is applicable to the need of the monitoring station of the atmospheric environment to be far away from the actual site.*
- *Multiple communication interface options, connect monitoring and analysis software platform, to realize data storage, data analysis and comparison*
- *Get real-time data and analysis for the vast local area intensive observation points, or as a comparison of indoor data.*

Tongdy Sensing Technology Co., Ltd. as a national high-tech enterprise, over the past 12 years has been focused on the development of environmental air quality monitoring and control products and Solutions. Our environmental monitoring products have been exported to Europe, North America, Australia, the Gulf region for 12 years, and have a wide range of project applications. Our air monitoring products have long been used in Europe and many domestic government projects, gained very high visibility in the same industry.

Product Features

This TFA -17 series of air environmental monitoring instrument is specially designed for atmospheric environmental air quality monitoring, is suitable for the severe environment air quality in real-time on-line monitoring, its superior performance and quality, has a very high cost performance. With the budget of the air quality monitoring equipment, which is far below the meteorological level, the air quality real-time on-line monitoring of the air quality of the local area is easily expanded.

Adopt unique proprietary sensing module, fully enclosed casting aluminum structure design, to ensure the stability of the gas closed structure and shielding, greatly improve the anti-interference ability And module includes a large flow blower oil bearing, USES the automatic constant flow control technology, has a very high long-term operation stability and longevity

It is specially designed to protect the structure and housing of weather-proof and anti-aging solar radiation shield with a wide range of environmental adaptability.

With the function of temperature and humidity compensation, the influence of temperature and humidity changes on the measurement coefficients is reduced.

Real-time monitoring parameters: fine particulate matter (PM2.5) inhalable particulate matter (PM10) total suspended particulate matter (TSP) carbon dioxide (CO2) volatile organic compounds (TVOC)

ambient temperature ambient humidity.

Provide GPRS WIFI RS485 Modbus RJ45 Ethernet communication interface, optional.

It provides the interchangeable module components specially for regular maintenance, which makes the continuous data complete and reliable, and the regular maintenance is more convenient.

Connection data collection and analysis software platform, the realization of multiple local observation point data storage than in data analysis, determine the pollution sources, the environment air pollution source to the atmosphere to provide data support for improving the atmospheric environmental air quality get a lot of analysis data and basis

With MSD - a series of indoor air quality monitor, data can be used as indoor and outdoor air quality than the same area, solved due to the atmospheric environmental monitoring sites away from the real environment, so the data error caused by provides improved indoor air quality with the basis of a more effective

With TFA - 18 series air environment monitor, extensible choice: ozone (O₃), carbon monoxide (CO), sulfur dioxide (SO₂), nitrogen dioxide (NO₂) was applied to atmospheric air environmental monitoring, to form a small air quality monitoring station is applied in more atmosphere or half atmosphere, underground or semi-underground space , and etc.

Application Cases

.1. TFA-17 series + tfa-18 series are Shared, and the monitoring environment parameters include: PM2.5/PM10 /TSP CO₂ TVOC O₃ CO SO₂ NO₂ temperature and humidity.

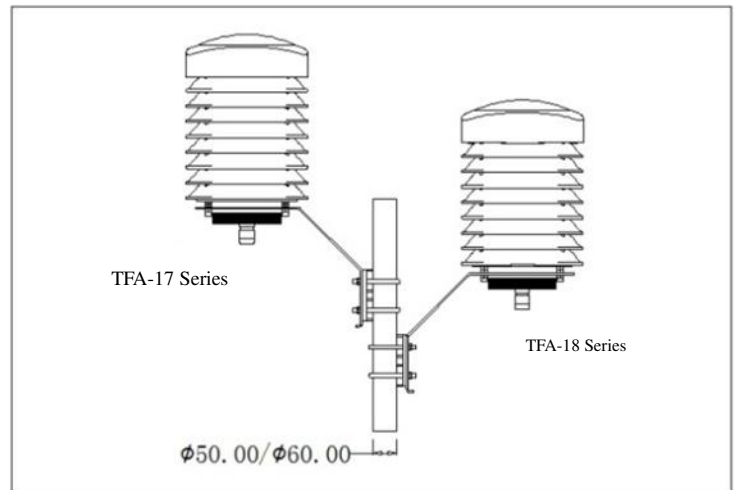

2. TFA-17 series (atmospheric environment monitoring) and MSD indoor IAQ monitoring series are used together to achieve the comparison of indoor and outdoor air quality data in the same area.

MSD -Series (indoor environment)



TFA-17(atmospheric environment)



3. Local area regulation, multi-point real-time data collection.

- Key regulatory industry
- enterprises with pollutants
- Temporary construction site



Models Guide

Model	PM2.5	PM10	Total Grain	Temp/ RH	CO2	TVOC	Main Applications	Output
TFA-1712C	●	●	●	●			atmospheric environment	RS485 (Modbus RTU)
TFA-1713C	●	●	●	●	●		Semi-atmospheric environment/tunnel/subway/underground facility/plant/workshop, etc.	
TFA-1714C	●	●	●	●	●	●		
TFA-1742C	●	●	●	●			atmospheric environment	GPRS (2G) + GPS (mobile, China Unicom)
TFA-1743C	●	●	●	●	●		Semi-atmospheric environment/tunnel/subway/underground facility/plant/workshop, etc.	
TFA-1744C	●	●	●	●	●	●		
TFA-1732C	●	●	●	●			atmospheric environment	RJ45

TFA-1733C	•	•	•	•	•		Semi-atmospheric environment/tunnel/subway/underground facility/plant/workshop, etc.	(Ethernet TCP)
TFA-1734C	•	•	•	•	•	•		
TFA-1722C	•	•	•	•			atmospheric environment	WiFi @2.4 GHz 802.11b/g/n
TFA-1723C	•	•	•	•	•		Semi-atmospheric environment/tunnel/subway/underground facility/plant/workshop, etc.	
TFA-1724C	•	•	•	•	•	•	facility/plant/workshop, etc.	

Basic Specifications

General Data	
Power supply	12-24Vdc >500mA DC voltage stabilized linear power supply, can be directly connected to 220~240VAC power supply
Output	Four optional outputs followed
RS485	RS485/RTU, 9600bps (default), 15KV ESD protection
RJ45	Ethernet TCP
Wireless communication function	- WiFi@2.4 GHz 802.11b/g/n - GPRS (2G) + GPS
Measurement interval	60 seconds (set)
Operating Environment	-20 ~60 C / 0~99%RH, no condensation
Storage Conditions	0°C~50°C / 10~60%RH
Overall Dimension(without bracket)	Diameter 190.00mm, (GPRS: height 324mm) ; (WiFi ,RS485, RJ45: height 300mm)
Mounting accessories (bracket)	4.0mm metal support plate, 228.00mm(L)x152.00mm(W)x160.00mm(H)
Maximum size (including fixed bracket)	Overall Length: 272mm, overall Width: 190mm, overall height: (GPRS 434mm) ; (WiFi ,RS485, RJ45 410mm)
Net weight	2650g (GPRS) , 2530g (WiFi ,RS485, RJ45)
Material of Housing	PC material
Protection grade	Cover housing is equipped with a sensor inlet filter, Rain proof, high and low temperature resistance, resistance to ultraviolet radiation aging, solar radiation protection / IP53
Fine particles (PM2.5)/ respirable particles (PM10)/ total suspended particles (TSP) related data	
Sensor	Laser particle sensor, Light scattering method
Measuring Range	PM2.5: 0~1000 $\mu\text{g}/\text{m}^3$; PM10: 0~3000 $\mu\text{g}/\text{m}^3$; TSP: 0~5000 $\mu\text{g}/\text{m}^3$
Output Resolution	0.1 $\mu\text{g}/\text{m}^3$
Zero Point Stability	<3 $\mu\text{g}/\text{m}^3$
Accuracy of PM2.5(mean per hour)	< $\pm 3 \mu\text{g}/\text{m}^3 + 10\%$ of reading (PM2.5, 0~1000 $\mu\text{g}/\text{m}^3$, 25°C, 10~80%RH)
CO2 Data	
Sensor	Non-Dispersive Infrared Detector (NDIR)

Measuring Range	0~2,000ppm
Output Resolution	1ppm
Accuracy	±50ppm +3% of reading or ± 75ppm (whichever is larger) (25°C, 10%~80%RH)
Temperature and Humidity Data	
Sensor	Capacitive humidity sensor with gap material temperature sensor.
Measuring Range	Temperature : -20°C~60°C / Humidity : 0~99%RH
Output Resolution	Temperature : 0.01°C / Humidity : 0.01%RH
Accuracy	Temperature : <±0.5°C@25°C Humidity : <±3.0%RH (20%~80%RH)
Stability	Temperature: <0.04 degrees C (annual) humidity: <0.5%RH (per year)
Volatile organic compounds (TVOC)(option)	
Sensor	TVOC (With waterproof breathable hood.)
Measuring Range	0~ 3.5mg / m ³
Output Resolution	0.001mg / m ³
Accuracy	<±0.10mg/m ³ +15% of reading (0~2.0mg / m ³) , 25°C, 10~80%RH)

Installation drawing of external structure (GPRS)

Dimensions: Dimensions: 272.00mm long; 190.00 mm wide; 434.00 mm high

Net weight: 2650 grams.

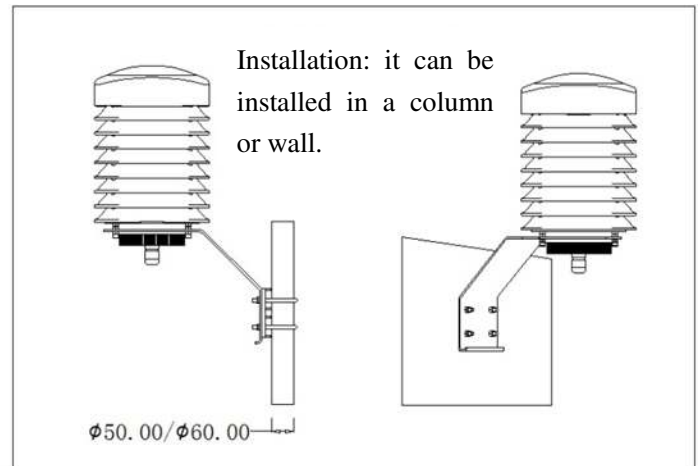
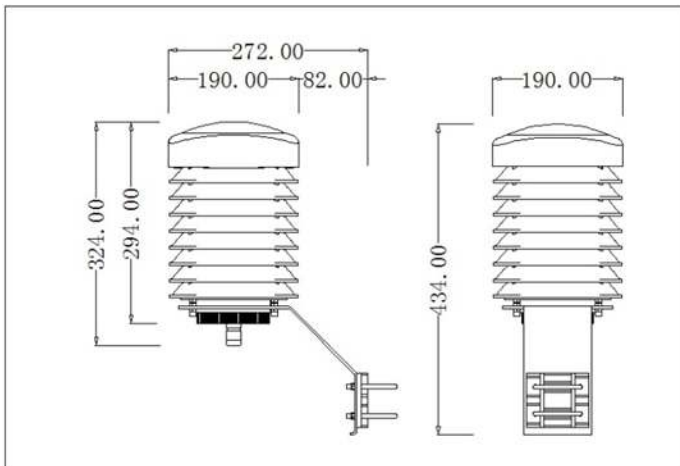

Installation drawing of external structure (WIFI, RS485, RJ45)

Dimensions: 272.00mm long; 190.00 mm wide; 410.00 mm high

Net weight: 2530 grams

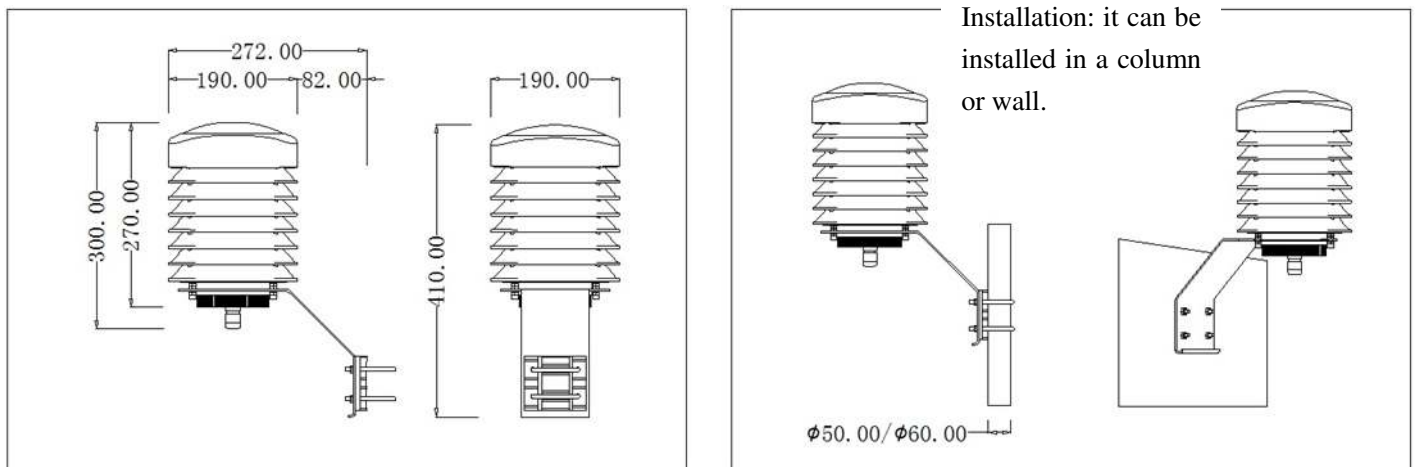

Other related IAQ products.

- MSD- series indoor high precision air quality monitor - commercial grade, RESET certification, meeting public building monitoring and green building assessment requirements.
- PMD- series air quality detector - commercial grade, RESET certification to meet the needs of public building monitoring and green building assessment.
- TSP- a series of indoor air quality monitors - similar to most monitors in the market to meet smart home systems and small office environments.
- TFA-18 series of atmospheric air environment monitoring equipment - air pollutant monitoring, used in underground garage tunnel industrial environment and other tests.



Tongdy Sensing Technology

Building 8, Courtyard 9, Dijing Rd., Haidian Dist., Beijing

info@tongdy.com

+86-10 59738936/37

www.tongdy.com